

## PLACEMENT

Your local postmaster must approve the location of your mailbox.

Put a roadside mailbox where a carrier can reach inside without leaving the truck. That means positioning it about 41" to 45" off the ground and back about 6" to 8" from the curb.

If you live in the city and are attaching the box to your house, just make sure it can be accessed easily from your sidewalk, steps, or porch. Because city carriers often shoulder heavy bags, put your mailbox about 4' from the ground. That way, your carrier won't have to stretch or bend to reach it. And remember to keep the path to your mailbox clear in inclement weather.

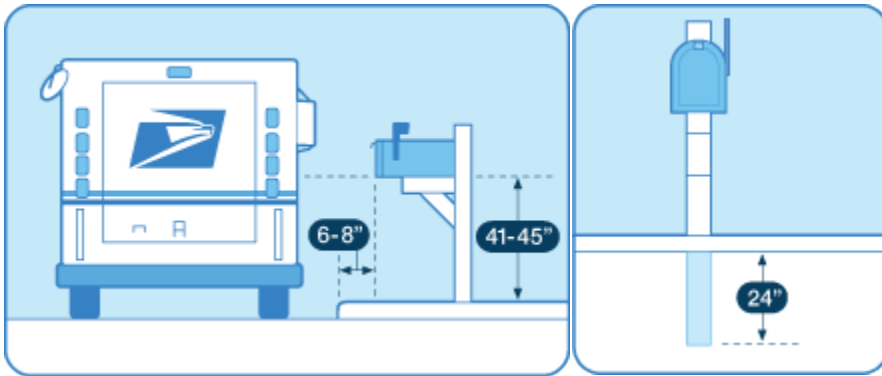

## THE POST

If you're mounting a curbside mailbox on a post near the street, the support should be secure and safe. The best supports are designed to bend or fall away if a car hits them.

The Federal Highway Administration recommends...

- a wooden mailbox support no bigger than 4" x 4".
- a 2"-diameter standard steel or aluminum pipe.

Bury your post no more than 24" deep, so it can give way in an accident.

Don't use potentially dangerous supports, such as...

- heavy metal pipes.
- concrete posts.
- farm equipment, such as milk cans filled with concrete.

In areas with lots of snow, we suggest a semi-arch or extended arm-type support. That way, snowplows will be able to sweep under without knocking it down.

## MAINTENANCE

Your mailbox takes a serious beating from the weather, especially in the winter. We suggest a routine mailbox check-up every spring.

You might just need to...

- Replace loose hinges on the door.
- Repaint rusty or peeling parts.
- Remount the post, if it's loose.
- Replace missing or faded house numbers.

And year-round keep obstructions away from your mailbox. Your carrier may not deliver your mail if there's a car, shrub, snowdrift, or unfriendly dog in front of it.