



Lower Southampton Township
 Bucks County, Pennsylvania
 1500 Desire Avenue – Feasterville, PA 19053
 Phone: (215) 357-7300 – E-Mail: permits@lstwp.org

****OFFICE USE ONLY****

Date Received: _____

Permit No.: _____

ZONING PERMIT APPLICATION

I. PROPERTY INFORMATION (each line item MUST be completed)

WORK SITE ADDRESS:

Tax Parcel: **21-**

Property within a Floodplain: Yes No *If yes, what is the market value of the property:*

II. CONTACT INFORMATION (Each line item MUST be completed)

Please be Advised: ONLY APPLICANT receives correspondence and/or permit.

PROPERTY OWNER:

Mailing Address: _____ City: _____ State: _____ Zip: _____

E-Mail: _____ Phone No: _____

APPLICANT:

Mailing Address: _____ City: _____ State: _____ Zip: _____

E-Mail: _____ Phone No: _____

⚠ *Please be Advised: If this application submission does not include contractor info. and/or left blank, it will be assumed home owner is to perform all work contained within.*

CONTRACTOR:

Mailing Address: _____ City: _____ State: _____ Zip: _____

Person in charge of work:

E-Mail: _____ Phone No: _____

Insurance Company: _____ Policy No: _____ PA Hic License: **PA**

DESIGN PROFESSIONAL:

Mailing Address: _____ City: _____ State: _____ Zip: _____

Person in charge of work:

E-Mail: _____ Phone No: _____

III. CONSTRUCTION (COMPLETION MANDATORY)

DECK *below 30" in grade & less than 150 square feet** Size: _____ (length) X _____ (width) X _____ (height)

FENCE Size: _____ (height) **Total Linear Feet:** _____

PATIO *less than 150 square feet** **Total Square Feet:** _____ Size: _____ (length) X _____ (width) X _____ (height)

STRUCTURE (new) *less than 150 square feet**

Accessory Principal **Total Square Feet:** _____ Size: _____ (length) X _____ (width) X _____ (height)

STRUCTURE (add to existing) *less than 150 square feet**

Accessory Principal **Total Square Feet:** _____ Size: _____ (length) X _____ (width) X _____ (height)

OTHER *please specify*

***ANY STRUCTURE, PATIO OR DECK above 30" grade & 150sf or MORE TO BE SUBMITTED ON PA UCC CONSTRUCTION PERMIT APPLICATION**

PROJECT TOTAL COST: \$ _____

IV. DESCRIPTION OF WORK (COMPLETION MANDATORY)

Provide a detailed narrative which explains the proposed project.

V. PLOT PLAN INSTRUCTIONS

PLEASE INCLUDE THE FOLLOWING:

1. Indicate the length of all property lines.
2. Show all existing and proposed structures on property and the distance from the structure to the property lines.
3. Indicate name of streets abutting property.
4. Identify all bodies of water and show distance to proposed structure(s).
5. Show septic, well, driveway locations and distance from new structure to septic.
6. Label distances from principal structure to proposed accessory structure(s).
7. Physically mark property lines & proposed location of structure onsite prior to submitting zoning application.

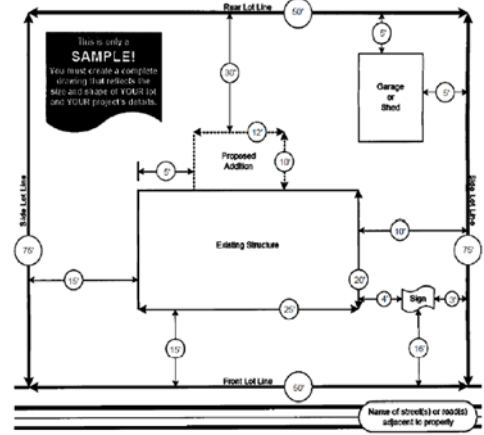

VI. PLOT PLAN DRAWING (MANDATORY)

A survey or other prepared plot plan can be attached, in lieu of this sketch sheet.

VII. SUBMISSION REQUIREMENTS (MANDATORY)

- Digital submission e-mailed to mitalia@lstwp.org
MUST include Zoning Permit Application (3 pages) and detailed plans where applicable.

VIII. APPLICANT'S CERTIFICATION (Applicant Signature MANDATORY)

As the owner or the authorized agent of the project for which this application is filed, I CERTIFY THAT:

1. The inspector is hereby granted access to observe the work in this application upon coordination with the owner or his agents.
2. The estimated construction cost and all other information provided as part of this application for a zoning permit is correct.
3. The building or structure described in this application will not be occupied until all known code violations are corrected and a Certificate of Occupancy has been received from Building Code Official.
4. This project will be constructed in accordance with the approved drawings and specifications (including any required non-design changes) and the Uniform Construction Code standards as specified in 34 PA Code Chapters 401-405.
5. Any changes to the approved documents will be filed with the Building Code Official.
6. If the licensed architect or engineer in responsible charge of this construction should change, written notice of the change will be provided to the Building Code Official.
7. When required, up to 20% of the total cost of any work performed on an area of primary function in an existing building will be expended to provide an accessible route to the area of primary function or other approved accessibility improvements.
8. No error or omission in either the drawings and specifications or application, whether approved or not, shall permit or relieve me from constructing the work in any manner other than provided for in 34 PA Code Chapters 401-405.

Applicant Signature: _____ Date: _____

Applicant Name (Print): _____

FAILURE TO FILL OUT PERMIT APPLICATION COMPLETELY MAY RESULT IN DELAYS OR REJECTION OF APPLICATION

**** OFFICE USE ONLY ****

APPROVED PERMITS

Zoning Permit No.: _____ NPDES Permit No.: _____

Sewage Permit No.: _____ Water Permit No.: _____

PROJECT DATA

Use Group: _____ Code Edition: _____

Construction Type: _____ Fire Sprinkler: Y N

DECISION

Approved Denied

Approved by: _____ Approval Date: _____